

# STAINED GLASS CARDIE

designed by Hélène Rush

PATTERN NO. 1856 • Intermediate

## FINISHED BUST SIZES

36.25 40 43.25 47 50.75 in.

## FINISHED LENGTHS

21 21.5 22 22.5 23 in.

## MATERIALS

### Knit One, Crochet Too® Yarn

Geologie (50-gr/120-yd, 55% wool/45% acrylic):

7 8 9 9 10 balls Jadeite #533 (A)

1 ball each Spectrolite #651 (B) and Amethyst #745 (C)

**Needles:** One each US size 8 (5 mm) and 10 (6mm) needles,  
or size to obtain gauge

## GAUGE

In St st, using smaller needles, 18 sts = 4 in./10cm

To save time, take time to check gauge.

## SPECIAL TECHNIQUE

**3-Needle Bind Off:** Place sts from each shoulder holder onto separate needles, points parallel and facing same direction. Holding these with RS tog, and with a 3rd same size needle, (insert needle in first st from front needle and first st from back needle, and k2 tog) twice, \* pass first st from RH needle over 2nd to BO, knit next 2 sts from LH needles tog as before; rep from \* until 1 st rem. Fasten off.

## PATTERN STITCH

### Cathedral Pat

multiple of 4 sts; work over 26 rows

Row 1 (RS): K3A, \* p2B, k2A; rep from \* across, k1A.

Row 2: P3A, \* k2B, p2A; rep from \* across, p1A.

Rows 3 and 4: Rep Rows 1 and 2.

Row 5: K3A, \* p2C, k2A; rep from \* across, k1A.

Row 6: P3A, \* k2C, p2A; rep from \* across, p1A.

Rows 7 and 8: Rep Rows 5 and 6.

Rows 9–16: Rep Rows 1–8.

Row 17: K1A, p1B, \* drop next st to front, p1B, pick up dropped st with LH needle, knit it with A, sk next st, k1A, purl skipped st with B; rep from \* across, p1B, k1A.

Row 18: P1A, \* k2B, p2A; rep from \* across, k2B, p1A.

Row 19: K1A, \* p2B, k2A; rep from \* across, p2B, k1A.

Row 20: Rep Row 18.

Row 21: K2A, \* sk next st, K1A, purl skipped st with C, drop next st to front, p1C, pick up dropped st with LH needle, knit it with A; rep from \* across, k2A.

Row 22: P3A, \* k2C, p2A; rep from \* across, p1A.

Row 23: K3A, \* p2C, k2A; rep from \* across, k1A.

Row 24: Rep Row 22.

Row 25: Using A across entire row, k1, p1, \* drop next st to front, p1, pick up dropped st with LH needle and knit it, sk next st, k1, purl skipped st; rep from \* across, p1, k1.

Row 26: Using A across entire row, p1, \* k2, p2; rep from \* across, k2, p1.



## BACK

Using larger needles and A, CO

80 88 96 104 112 sts.

Beg Cathedral Pat and work through Row 26.

Using smaller needles, beg St st with A, and work even until Back measures 13.5 in. from beg, ending with a WS row.

### Shape Armhole: BO

5 6 7 8 9 sts at beg of next 2 rows,

dec 1 st each side eor

6 7 8 8 9 times—

58 62 66 72 76 sts rem.

Work even until armhole measures

5.5 6 6.5 7 7.5 in. from beg, ending with a WS row.

### Shape Neck: Knit across

17 18 19 21 22 sts; turn leaving rem sts on hold.

Dec 1 st at neck edge eor 3 times—

14 15 16 18 19 sts rem.

Work even until armhole measures

7.5 8 8.5 9 9.5 in. from beg.

Place sts on holder.

To complete other side, place center

24 26 28 30 32 sts on holder for back of neck,  
and work on rem sts to match first side.

## LEFT FRONT

Using A and larger needles, CO

40 44 48 52 56 sts.

Work as for Back, shaping armhole at beg of RS rows, working until Left Front armhole measures

3.5 4 4.5 5 5.5 from beg, ending with a WS row—  
29 31 33 36 38 sts rem once armhole shaping is completed.

**Shape Neck:** Knit across

19 20 21 23 24 sts; turn, placing rem  
10 11 12 13 14 sts on holder.

Dec 1 st at neck edge eor 5 times—

14 15 16 18 19 sts rem.

Work even until same length as Back to shoulder.

Place sts on holder.

## RIGHT FRONT

Work as for Left Front, reversing armhole and neck shaping.

## SLEEVES

Using A, CO

52 56 56 60 64 sts.

Beg Cathedral Pat and work through Row 26.

Using smaller needles, beg St st with A, dec

9 9 7 9 9 sts evenly in first row—

43 47 49 51 55 sts rem.

Cont in St st, WHILE AT THE SAME TIME, inc 1 st each side every

8 8 8 6 6 rows

8 8 9 10 10 times—

59 63 67 71 75 sts.

Work even until Sleeve measures

17 17 17.5 17.5 18 in. from beg, or desired length to underarm.

**Shape Armhole and Cap:** BO

5 6 7 8 9 sts at beg of next 2 rows,

dec 1 st each side eor

12 13 14 15 16 times—25 sts rem.

BO 2 sts at beg of next 6 rows.

BO rem 13 sts.

## FINISHING

Join shoulders using 3-Needle BO method.

**Neckband:** RS facing, using larger needles and A, knit across

10 11 12 13 14 sts from Right Front neck holder,  
pick up and knit 22 sts on front side of neck, and 10 sts on back side  
of neck, knit across

24 26 28 30 32 sts from Back neck holder,

pick up and knit 10 sts on back side of neck, and 22 sts on front  
side of neck, knit across

10 11 12 13 14 sts from Left Front—

108 112 116 120 124 sts.

**Beg color pat as follows:** Row 1 (WS): P3A, \* k2B, p2A; rep  
from \* across, p1A.

Row 2: K3A, \* p2B, k2A; rep from \* across, k1A.

Row 3: Rep Row 1.

Row 4: K1A, p1C, \* drop next st to front, p1C, pick up dropped  
st with LH needle, knit it with A, sk next st, k1A, purl skipped st  
with C; rep from \* across, p1C, k1A.

Row 5: P1A, \* k2C, p2A; rep from \* across, k2C, p1A.

Row 6: K1A, \* p2C, k2A; rep from \* across, p2C, k1A.

Row 7: Rep Row 5.

Change to smaller needles.

Row 8: K2A, \* sk next st, K1A, purl skipped st with B, drop next st to  
front, p1B, pick up dropped st with LH needle, knit it with A; rep from  
\* across, k2A.

Row 9: Rep Row 1.

RS facing, BO all sts purlwise using A.

**Buttonband:** RS facing, using larger needles and A,  
evenly pick up and knit

90 90 94 94 98 sts along Left Front edge

Row 1 (WS): P2A, \* k2B, p2A; rep from \* across.

Row 2: K2A, \* p2B, k2A; rep from \* across.

Row 3: P2A, \* k2C, p2A; rep from \* across.

Row 4: K2A, \* p2C, k2A; rep from \* across.

Row 5: Rep Row 3.

RS facing, BO all sts purlwise using A.

**Buttonhole Band:** Work as for Buttonband through Row 1.

Row 2 (RS): Work in est pat on

21 21 25 25 29 sts, \* (using A, k2 tog), (using B, yo  
twice), (using A, k2 tog, k1), (p2B, k2A) 2 times, p2B, k1A; rep from \*  
3 more times, (using A, k2 tog), (using B, yo twice), (using A, k2 tog, k1).

Row 3: Using A on A, and C on all B sts, work in est pat to first but-  
tonhole, using C knit in front and back of double yo; work across  
completing each buttonhole in same manner.

Complete to match Buttonband.

Sew buttons opposite buttonholes.

Set in sleeves at armhole opening. Sew underarm and side seams.

## Abbreviations

beg - beginning

BO - bind off

CO - cast on

cont - continue

dec - decrease

eor - every other row

est - established

inc - increase

k - knit

LH - left-hand

p - purl

pat - pattern

rem - remain(ing)

rep - repeat

RH - right-hand

RS - right side

sk - skip

st(s) - stitch(es)

tog - together

WS - wrong side

yo - yarn over

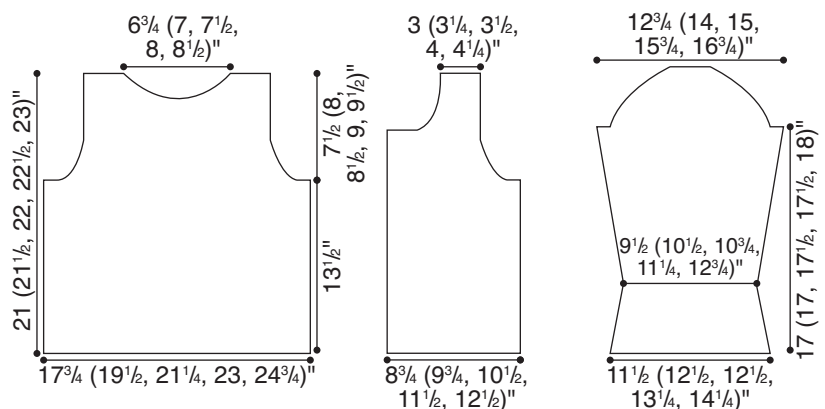

©2011, Knit One, Crochet Too, Inc., Windham, ME 04062

Although every effort has been made to ensure the accuracy of these instructions, Knit One, Crochet Too, Inc., cannot be held responsible for human or typographical errors, variations in individual work or misinterpretation of instructions. All Knit One, Crochet Too, Inc. patterns are authorized for non-professional, individual home use only. Copying this pattern for distribution is strictly forbidden. Find us at: [knitonecrochettoo.com](http://knitonecrochettoo.com) • [facebook.com/knitonecrochettoo](https://www.facebook.com/knitonecrochettoo) • iTunes Podcast: Knit One Crochet Too • [knitonecrochettoo.blogspot.com](http://knitonecrochettoo.blogspot.com)